

S.S.ENTERPRISES



Sourcing solution

An ISO 9001-2015 certified Company

Manufacturing, Wire Forming, Import/Export, Trading & more

About Us

- Works - H-143/1/4 MIDC Ambad, Nashik-422010
- Type of firm - Proprietorship
- Proprietor : Dr. Swati Deepak Darekar
- Contact person : Deepak Darekar (CEO), Yashraj Darekar (CEO)
- Mobile: + 91 9822591491, +91 7972562120
- E Mail: Sourcingssolution.sse@gmail.com
- Activity: Wire Forms Expert, Electrical Box Enclosure manufacturing, Automobile Interior part i.e plastic molding parts, Map pocket assembly, Hinges, Moldable Hardboard, Sun Visor Frames, Seating Assemblies, SPM Solutions, Import\Export, Trading items i.e Rivets, fasteners, Sleeve.
- GST No : **27 AJAPD5958M1ZV**
- Import/export code : **3111015912**

Turn Over

■ Turn Over

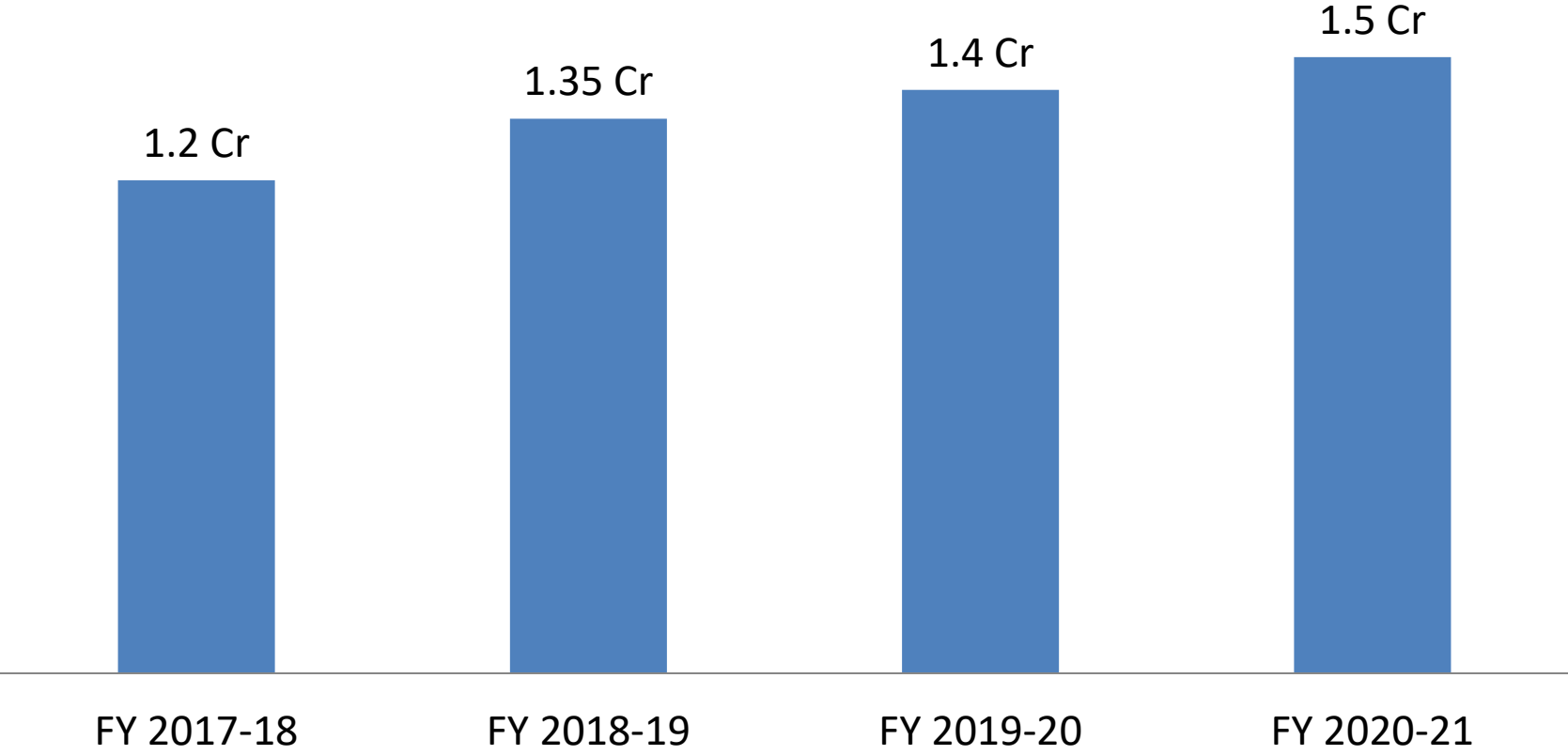

Company Profile

- We at S.S. Enterprises Manufacturer & supplies Press part, Machined part, plastic part .Auto interior parts & Engineering good
- We have design facility to manufacture mould, press tools, Jigs fixture, tooling & SPM as per customer concept.
- We have full fledged own manufacturing facility @ 10000 sq ft plus floor space in MIDC Ambad Nashik.
- We do the prototype developmet as per customer requirement.
- Apart from this we do sourcing consultancy & helps our client to develop local or international source for their product .
- We import Moldable hardboard / Engineering goods for Auto car manufacturer being used in door trim, seating & Engineering Industries.
- We are also trade engineering goods to various industries.
- Our clients are from Auto sector & Engineering company our products are being used in Auto cars i.e. XUV 500. TUV, KUV,XUV 300, TATA Harirer, Scorpio etc .

Facilities

1) Mechanical press set-up

- 75 ton -1 no
- 50 tons- 1 no
- 40tons – 2 no
- 20 tons – 2 no

2) Hydraulic press-3 no



Spot Welding M/C



- Mig welding M/C – 4Nos



- Arc Welding M/C – 2Nos



Wire Forming Facilities



Automatic Wire Forming Machine

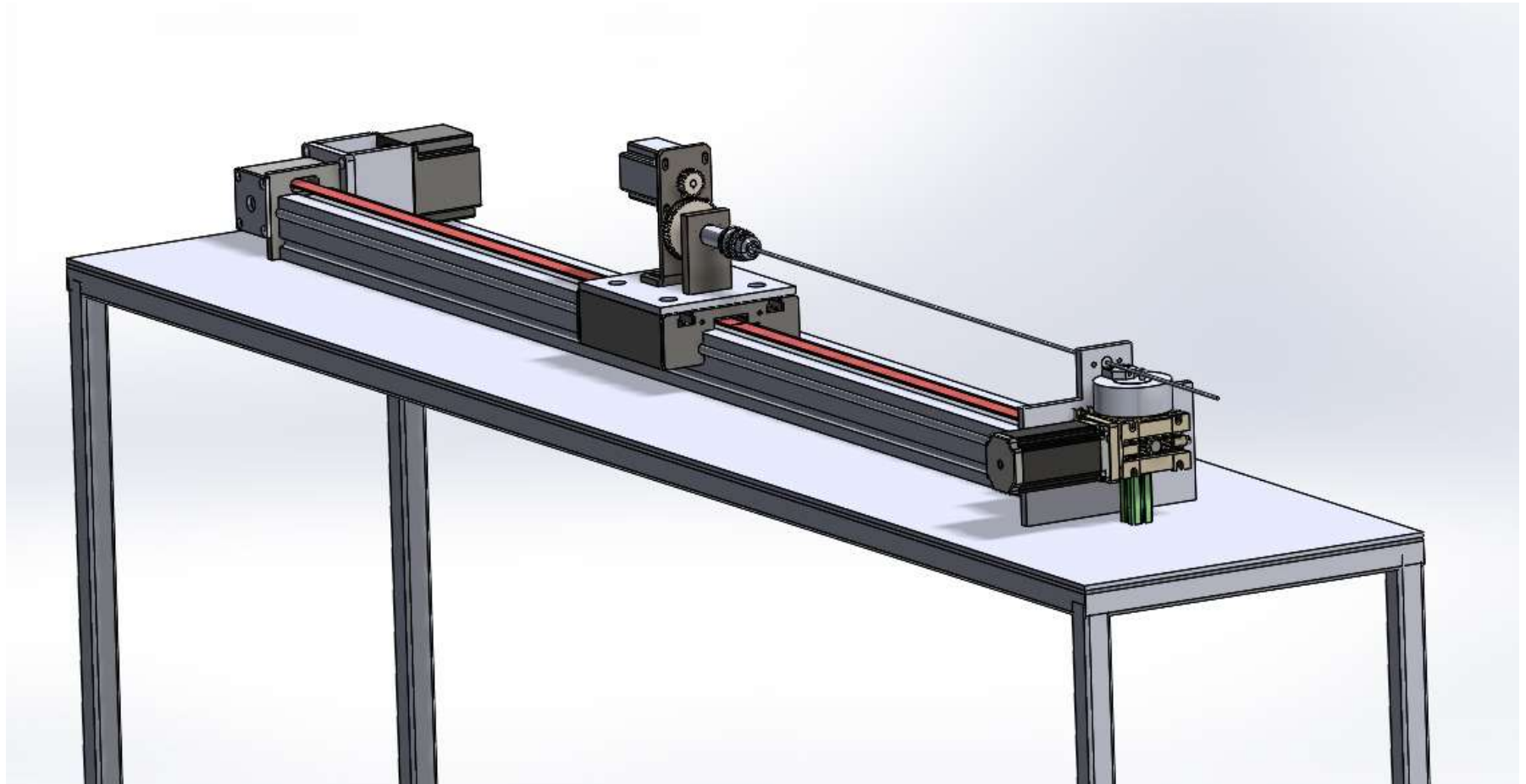

Our Products

Map Pocket used in Auto car



**Manufacture in-house &
supplies Map pocket to OEM**

Map/Paper Net used in Auto car



Wire Inserts -M.S./S.S./Spring steel



We have facility to mfg M.S./S.S./Spring steel wire inserts as per customer requirement

Press Part -Spring Hinge

(Production item 20000 /month)



Supplying to auto hardboard part manufacturer

Sheet metal Part

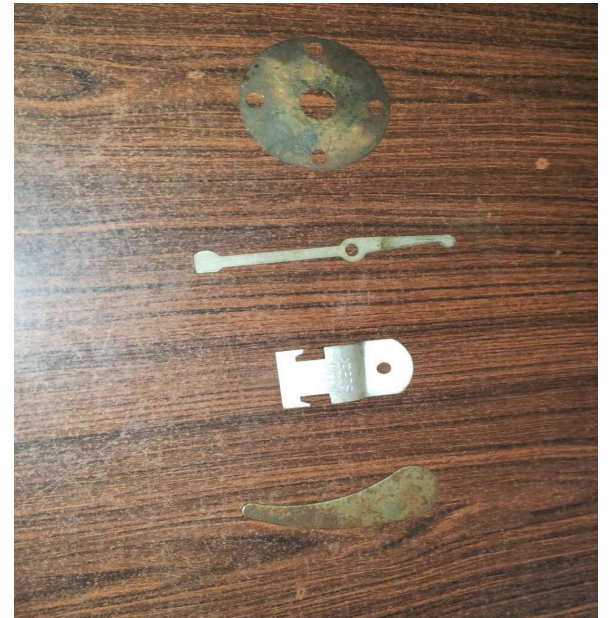

Press Part



Sunvisor wire Frame

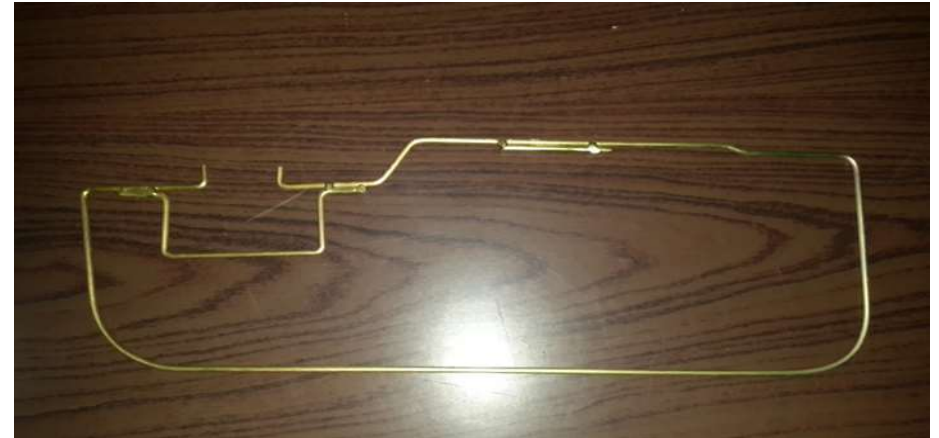

Production capacity of 50000 inserts per month

Sunvisor Frame

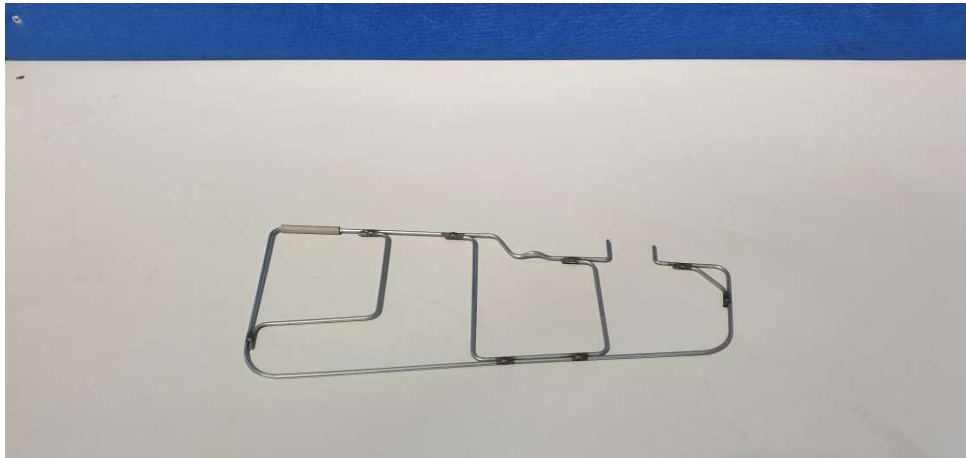

Wire frame

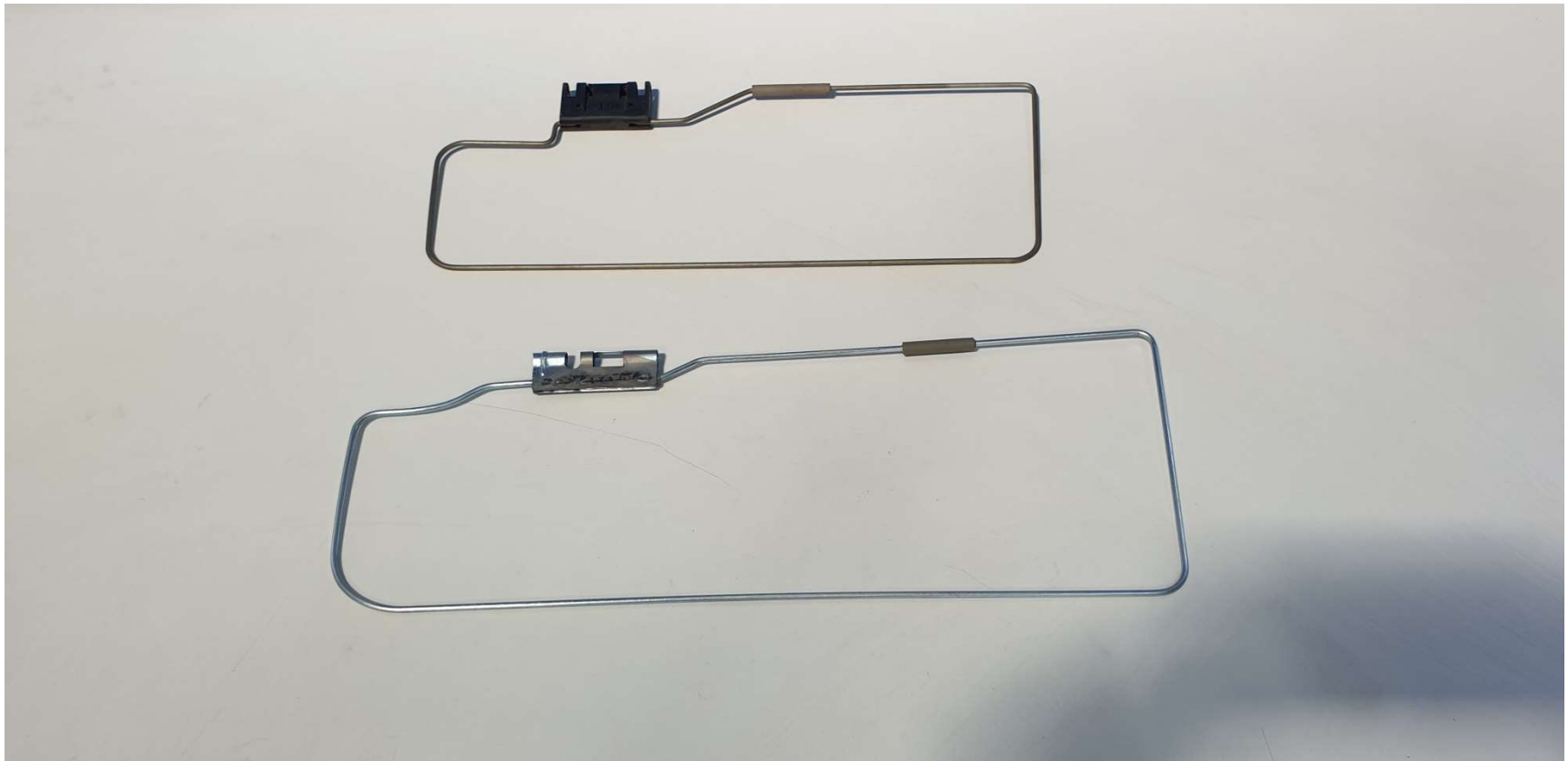

Electrical Enclosure Sheet Metal Box



Nylon string for back panel & P.P Elastic cord for Auto car used for Map Pocket /book holding net assly

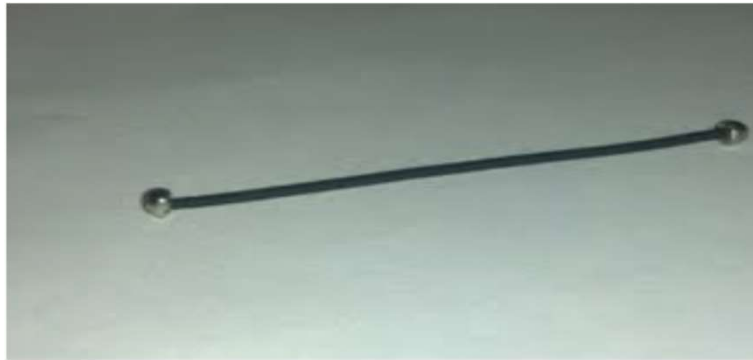

Used in net assembly in auto car .

Stainless steel callot used in map pocket /book holding net assly
designed crimping tool to crimp callot on elastic cord



Crimping tool



Designed Crimping tool to crimp callot

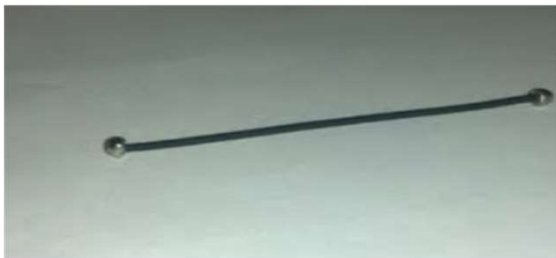

Used in net assembly in auto car .

Sheet metal/plastic part used in Engg/Auto Ind.

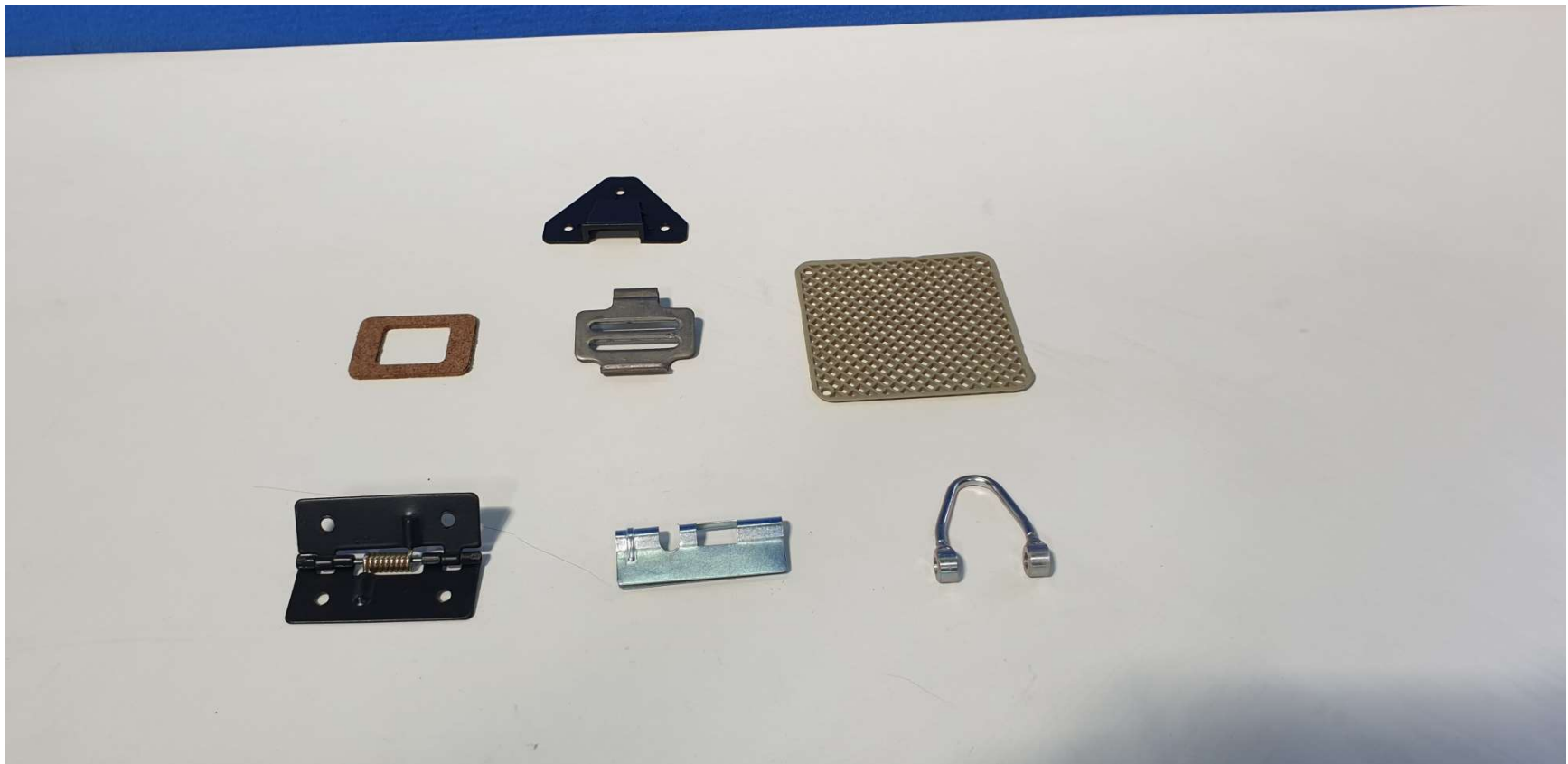

Auto Belt /Battery strap



Plastic Part used in Auto car



Auto car A/C vent



Plastic cup clip used in auto car seating back panel

(Production item 50000 /month)

Developed various plastic mould & We can also supply quality plastic part thru our group company .

Auto car Hardboard Semi finish

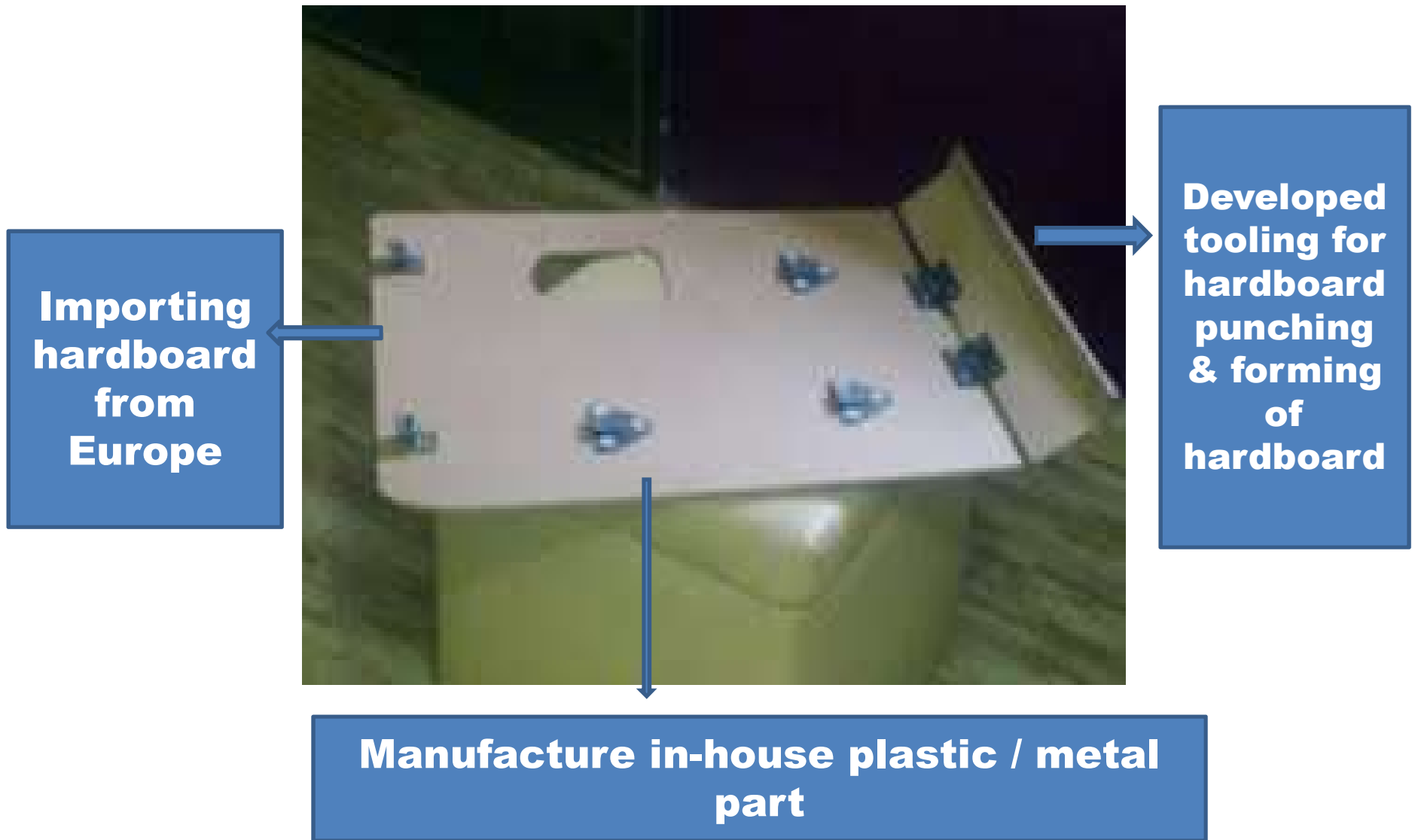

Import Hardboard from Europe for parts used in auto car.



Hardboard Punching /Forming tool -We have facility to design & manufacture Any presss tools upto 2 meter x 2 meter

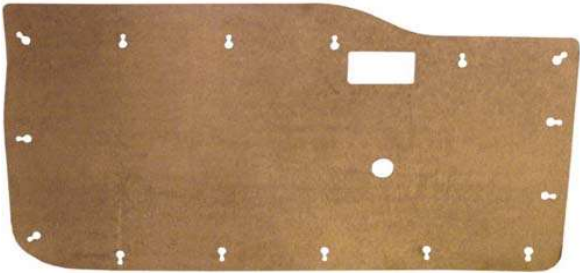

Supplies Imported rivet used in hardboard assembly. @ 2lakh pieces per month



Peel type rivet



Blind rivet used in metal part

foam mould for Auto car



Manufacture foam mould

Few Turned parts supplied by us .



Our End Consumers



UK Metal

